

# Conventional Sounder with strobe

MODEL: H-ABS-8

ASES sounder with strobes are audio and visual notification device used to alert trained personnel to investigate possible emergency situations and to take appropriate action. ASES Sounder with strobe is rich with features guaranteed to cut installation times and maximize profits. The sounders can be Flush/ceiling mounted with back plate. The strobe light consists of High glow LED Which give a strong light that can be visible from a long distance. These sounders are specially used in the noisy areas. These sounders can be used for indoor applicatin only.

## Features:

- **Audio and Visual warning.**
- **Plug-in structure and easy installation.**
- **Fast responding time low power consumption.**
- **Ceiling or Wall Mounting design.**
- **Used in Conventional Sounder circuit only.**
- **Temper-resistance construction.**



## Specification:

Material	<b>ABS Plastic</b>
Input Voltage	<b>6~24V DC</b>
Current	<b>5 ~ 120 mA</b>
Flash Intensity	<b>≥ 1.2 WS</b>
Flash Period	<b>≤ 1 Second</b>
Life of Flash Light	<b>≥ 100000 time</b>
Relative Humidity	<b>≥ 95%</b>
Operating Temperature	<b>-10 ~ 50° C</b>
Sound output	<b>90~103db @1 mtr</b>
Tone Type	<b>3 diffrent types of sound can be selected through jumper (Police car Sound, Fire Engine Sound, Ambulance, Sound)</b>
Size	<b>125(w) x 125(H) x 45(D)mm (Approx)</b>

## Wiring & terminal Details:

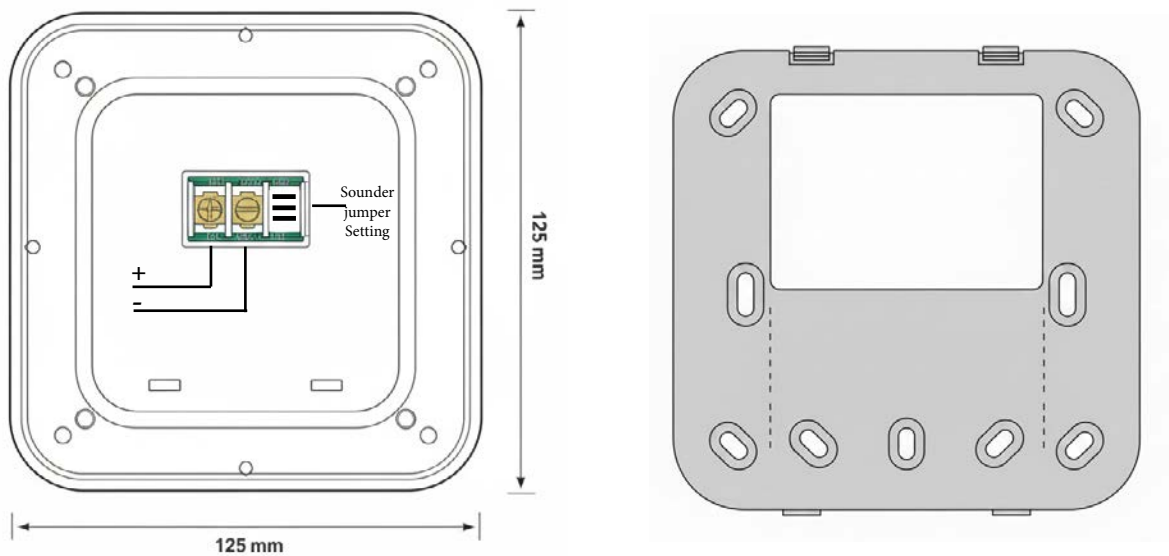

## Physical Dimension :

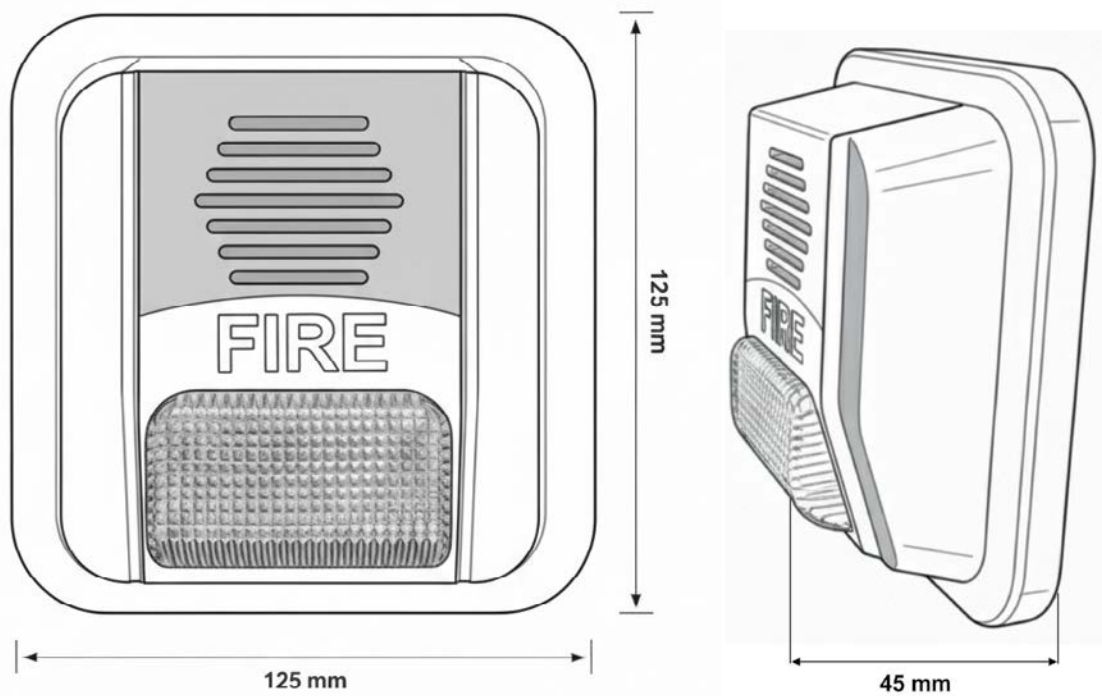

## Ordering Information

Part Number	Pack Quantity	Dimensions (WxHxD millimetres)	Weight (with packing box)
H-ABS-8	Individual(1 units)	128 x 126 x 55	207g (Approx)